

VS 勾配可変側溝

【東洋コンクリート】

T-25 タイプ

VS (Variable Slope)

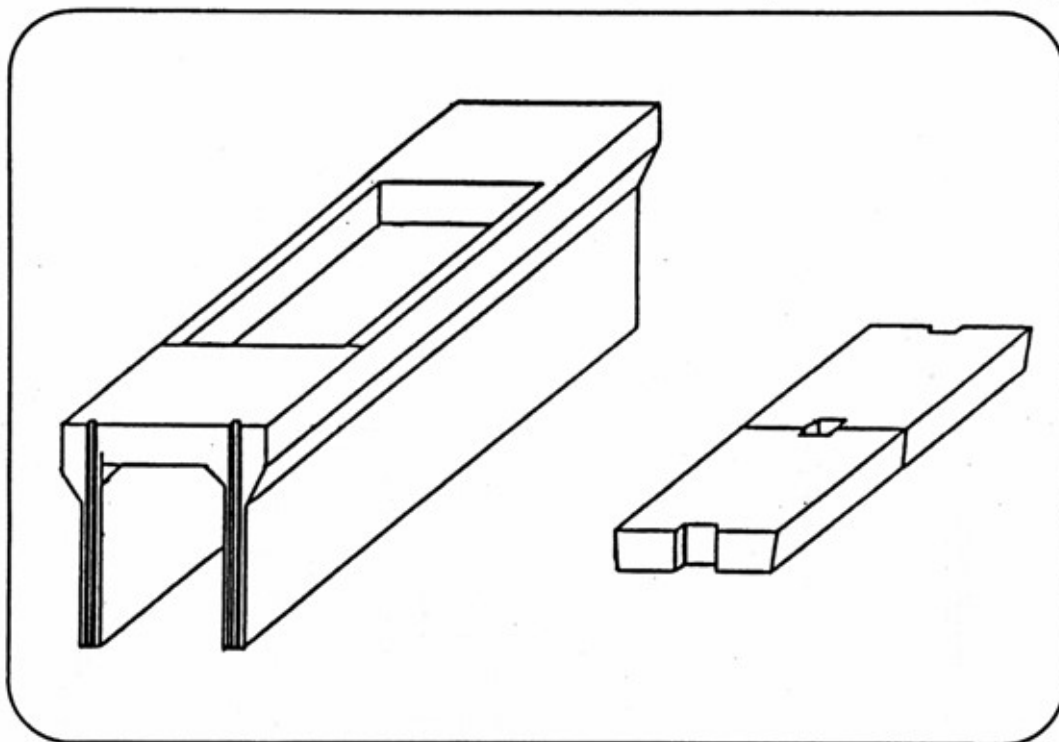

1. 道路勾配がほとんどない所でも底部に場所打ちコンクリートを施すだけで自由に排水勾配を取ることができます。
2. 道路幅員が狭く、水路幅に余裕のない箇所でも、壁の高さが10cmきざみのため水路の深さを自由にできますので便利です。
3. 今まで上記条件には、現場打ちしかありませんでしたが、この製品の出現により、工期は短縮され、工費も割安に上りますので、経済的です。

1. 標準基礎構造図

●基礎寸法表 (インバートコンクリート後打方式)

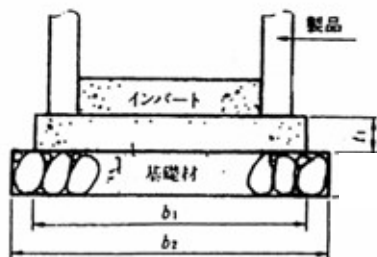

呼称	寸法 (mm)				
	t ₁	b ₁	b ₂		
縦断用	300	50	500~570	600~670	
	400		610~680	710~780	
	500	100	740~790	840~890	
	600		850~900	950~1000	
	700	120	1070	1170	
	800		1180	1280	
	900	150	1290	1390	
	1000		1400	1500	
	横断用	300	75	560~620	600~720
		400	100	670~730	770~830

東洋

VS側溝標準

規格図

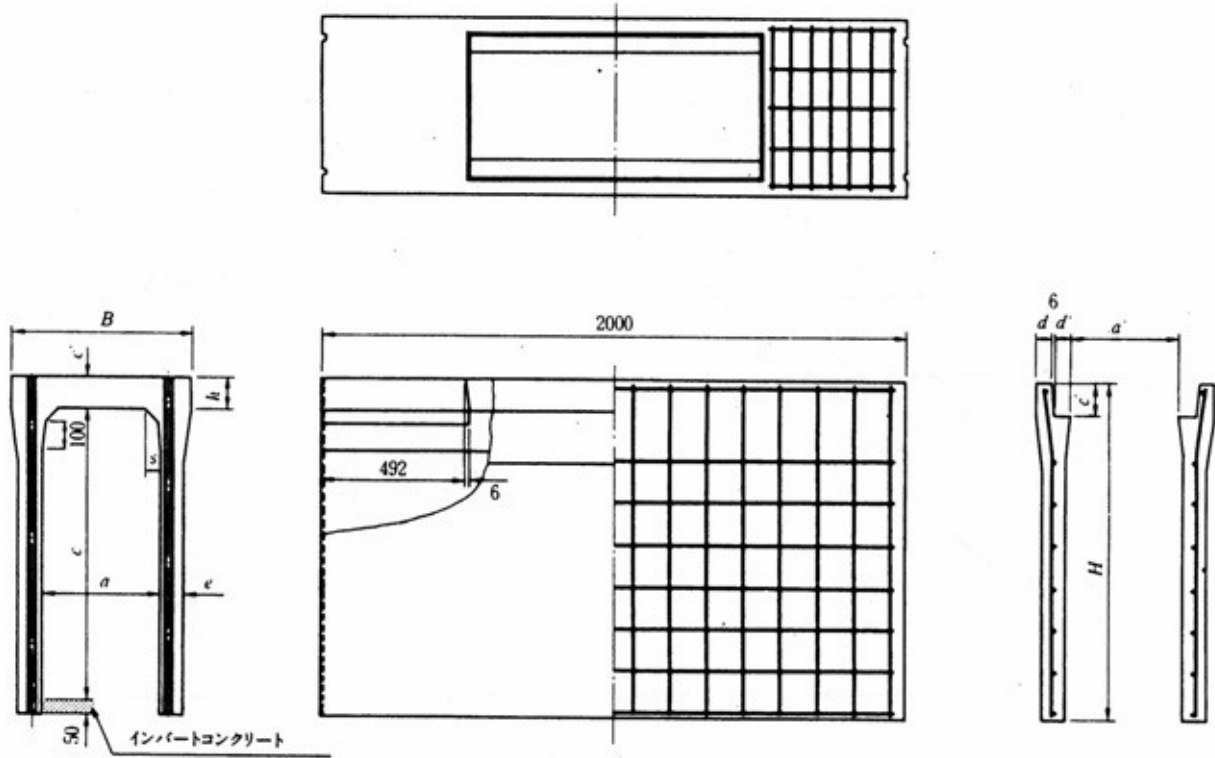

鉄筋コンクリート用蓋版

規格図

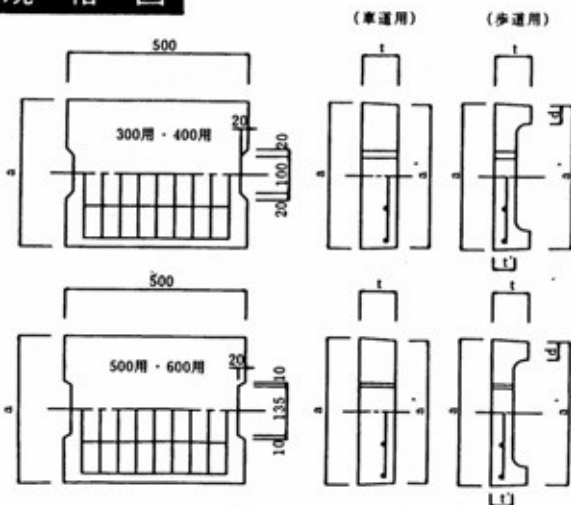

寸法・重量

呼び	寸法 (mm)					参考重量 (kg)	
	a	a'	d	t	t'		
車道用	300用	404	394	—	100	48	
	400用	504	494		120	72	
	500用	622	612		125	91	
	600用	732	722		140	120	
歩道用	300用	404	394	50	100	60	37
	400用	504	494	—	120	70	53
	500用	622	612	56	125	75	65
	600用	732	722	61	140	85	84

注) 配筋など詳細については、承認図面をご参照下さい。

寸法・重量

呼 び	寸 法 (mm)												参考重量 (kg)								
	B	H	a	a'	c	c'	d	d'	e	h	s	L									
300× 300	512	450	300	285	300	100	50	57.5	60	130	40	2,000	402								
× 400		550			400								460								
× 500		650			500								518								
× 600		750			600								576								
× 700		850			700								634								
× 800		950		800	724																
× 900		1,050		900	791																
× 1,000		1,150		1,000	858																
× 1,100		1,250		1,100	925																
× 1,200		1,350		1,200	992																
400× 400		632		570	400			377	400				120	60	61.5	70	140	40	2,000	635	
× 500	670		500	702																	
× 600	770		600	769																	
× 700	870		700	836																	
× 800	970		800	990																	
× 900	1,070		900	1,067																	
× 1,000	1,180		1,000	1,144																	
× 1,100	1,270		1,100	1,221																	
× 1,200	1,370		1,200	1,298																	
500× 500	740		675	500		470	500	125	55	75	80	150			50	2,000				728	
× 600			775				600													805	
× 700		875	700		882																
× 800		975	800		959																
× 900		1,075	900		1,101																
× 1,000		1,175	1,000		1,187																
× 1,100		1,275	1,100		1,273																
× 1,200		1,375	1,200		1,360																
600× 600		860	790		600		570			600	140		60	80			90	170	60	2,000	958
× 700			890							700											1,043
× 800			990							800											1,130
× 900	1,090		900	1,216																	
× 1,000	1,190		1,000	1,371																	
× 1,100	1,290		1,100	1,467																	
× 1,200	1,390		1,200	1,563																	
L長さ (1m)																					
300× 300	512		450	300		285		300	100	50		57.5		60	130	40	1,000				201
× 400			550					400													230
× 500			650					500													259
× 600		750	600		288																
× 700		850	700		317																
× 800		950	800		362																
× 900		1,050	900		396																
× 1,000		1,150	1,000		430																
× 1,100		1,250	1,100		464																
× 1,200		1,350	1,200		498																
400× 400		632	570		400	377	400	120			60	61.5	70	140				40	1,000	317	
× 500	670		500	351																	
× 600	770		600	385																	
× 700	870		700	419																	
× 800	970		800	495																	
× 900	1,070		900	533																	
× 1,000	1,180		1,000	571																	
× 1,100	1,270		1,100	609																	
× 1,200	1,370		1,200	647																	

グレーチング用 (固定式)

規格図

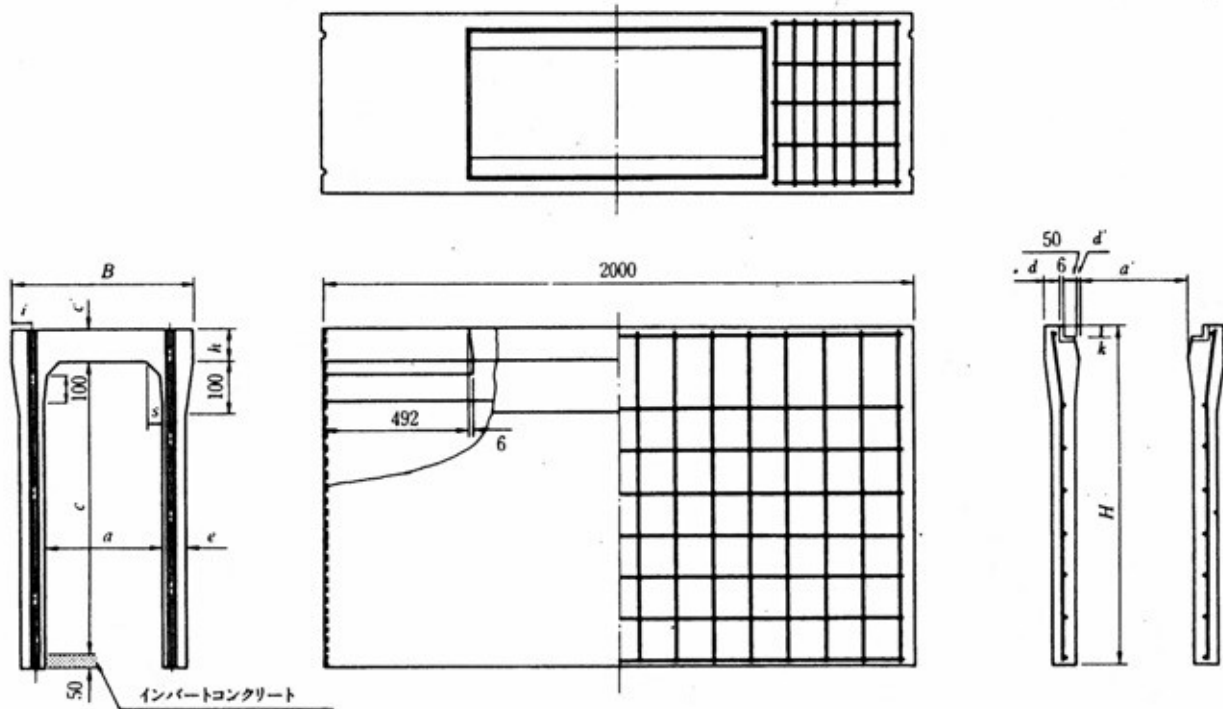

呼び	寸法 (mm)													参考重量 (kg)	
	B	H	a	a'	c	c'	d	d'	e	h	s	i	k		
300× 300×2,000	512	450	300	285	300	100	45	12.5	60	130	40	106	50	425	
× 400×2,000		550			400									483	
× 500×2,000		650			500									541	
× 600×2,000		750			600									599	
× 700×2,000		850			700									657	
× 800×2,000		950			800									715	
× 900×2,000		1,050	900	773	771										
×1,000×2,000		1,150	1,000	831	829										
×1,100×2,000		1,250	1,100	889	887										
×1,200×2,000		1,350	1,200	947	945										
400× 400×2,000		632	570	400	377	400	120	55	16.5	70	140	40	116	55	667
× 500×2,000			670			500									734
× 600×2,000	770		600			801									
× 700×2,000	870		700			868									
× 800×2,000	970		800			935									
× 900×2,000	1,070		900			1,002									
×1,000×2,000	1,170		1,000	1,069											
×1,100×2,000	1,270		1,100	1,136											
×1,200×2,000	1,370		1,200	1,203											
500× 500×2,000	740		675	500	476	500	125	59	17.0	90	150	50	120	65	751
× 600×2,000			775			600									818
× 700×2,000			875			700									885
× 800×2,000		975	800			952									
× 900×2,000		1,075	900			1,019									
×1,000×2,000		1,175	1,000			1,086									
×1,100×2,000		1,275	1,100	1,153											
×1,200×2,000		1,375	1,200	1,220											
600× 600×2,000		860	790	600	572	600	140	69	19.0	100	170	60	130	75	985
× 700×2,000			890			700									1,052
× 800×2,000			990			800									1,119
× 900×2,000			1,090			900									1,186
×1,000×2,000	1,190		1,000			1,253									
×1,100×2,000	1,290		1,100			1,320									
×1,200×2,000	1,390		1,200			1,387									

製品規格

本体規格

道路横断用製品(T-25)

規格図

(水路幅300-600)

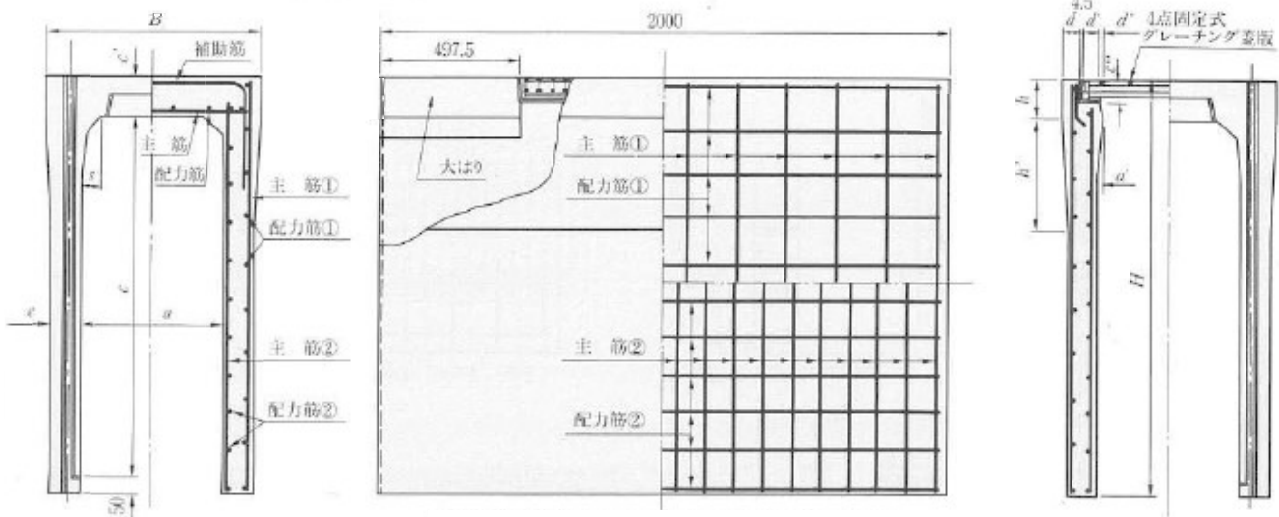

寸法・配筋・重量

配筋は片側当たり・方梁当たり

呼び名	寸法 (mm)														配筋										参考重量 (kg)					
	B	H	a	a'	C	C'	d	d'	d''	e	h	h'	s	側壁部				大はり部												
														主筋① 径(mm)	配筋① 径(mm)	主筋② 径(mm)	配筋② 径(mm)	主筋 径(mm)	配筋 径(mm)	補助筋 径(mm)	数									
300	×	300	445												D6 (D10)	10	4.0	4	4.0	15	3.2	4							475	
	×	400	545							80						13				13		5							550	
	×	500	645													17		6		16		6							624	
	×	600	745													19				18	4.0	7							780	
	×	700	845	300	277	885	110	60	50.5	64	2.5	95	110	300	45		7	5.0				7							868	
	×	800	945														11	5.0			19		8							957
	×	900	1,045														12						9							1,155
	×	1,000	1,145															8					8							1,257
	×	1,100	1,245															9					9							1,359
400	×	400	560													13				13		5							642	
	×	500	660													16		6		15		6							721	
	×	600	760													18						7							800	
	×	700	860													20				18		7							971	
	×	800	960	630	400	373	885	125	70	55.5	66	2.5	100	125	350	55		7	5.0		4.0	7							1,064	
	×	900	1,060														11	5.0				8							1,157	
	×	1,000	1,160														12					9							1,370	
	×	1,100	1,260															8				9							1,477	
	×	1,200	1,360															9				10							1,584	
500	×	500	675													16				16		6							971	
	×	600	775													19		6		18		7							1,087	
	×	700	875													10						8							1,203	
	×	800	975													11						9							1,319	
	×	900	1,075	750	500	468	885	140	75	65.5	68	3.0	95 (125)				7	5.0		4.0	7								1,435	
	×	1,000	1,175													11	5.0					8							1,551	
	×	1,100	1,275													12						9							1,667	
	×	1,200	1,375													13						10							1,783	
	×	1,300	1,475															10				11							1,899	
600	×	600	790													17				16		7							1,198	
	×	700	890													20		7		18		8							1,319	
	×	800	990																			9							1,440	
	×	900	1,090																			10							1,561	
	×	1,000	1,190	860	600	564	885	155	85	70.5	70	3.0	100 (130)				8	5.0		4.0	7								1,682	
	×	1,100	1,290													11						9							1,803	
	×	1,200	1,390													12						10							1,924	
	×	1,300	1,490																			11							2,045	
	×	1,400	1,590																			12							2,166	
×	1,500	1,690																			13							2,287		

注1 500、600タイプに関しては、構造計算は表示断面で行うが、実製品は最大断面で製作。()内表記

注2 使用鉄筋に関して、異形鉄筋D6を用いている箇所及び400~600タイプの大はり部配筋では、異形鉄筋D10を用いても良いものとする。()内表記

横断用 グレーチング 寸法・重量

呼び	寸法 (mm)				参考重量 (kg)	
	A	H(普通目)	H(細目)	L	普通目	細目
300用	400	55	55	995	34	46
400用	500	65	65	995	48	72
500用	600	69	68	995	64	91
600用	700	81	81	995	73	105

規格図

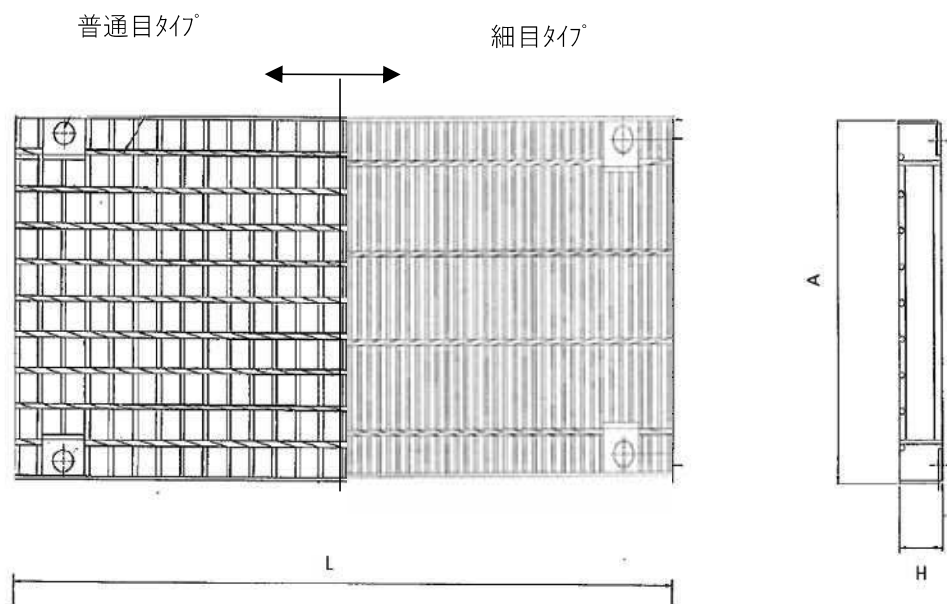

勾配可変側溝 街路V S

本体

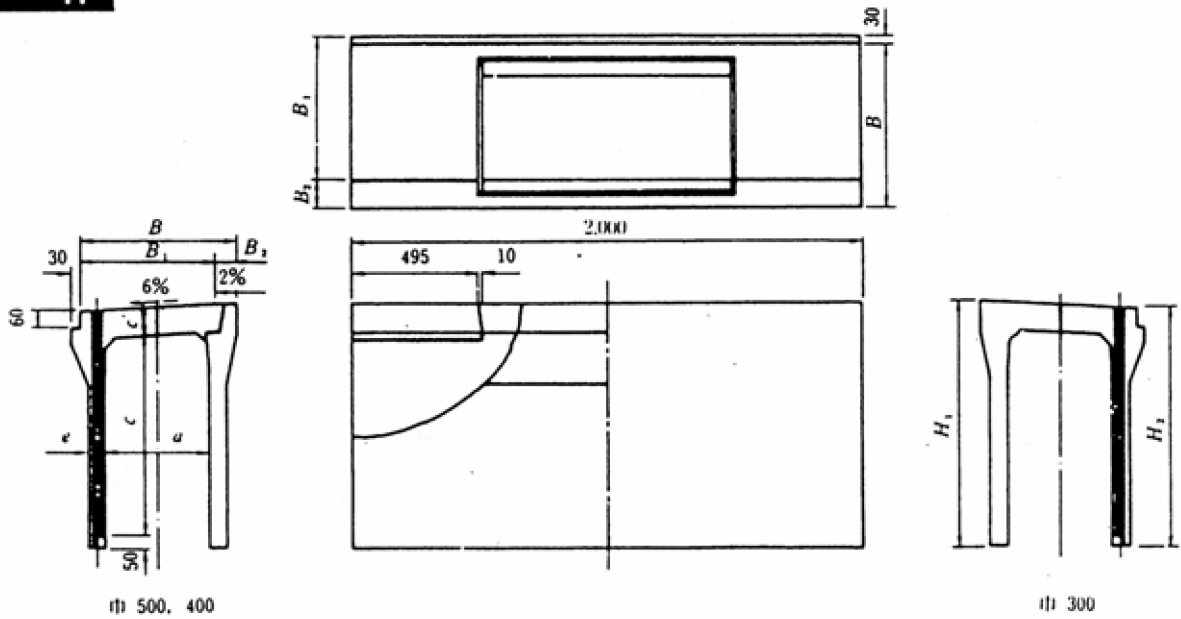

寸法・重量

呼び (巾×深)	寸法 (mm)									参考重量 (kg)				
	B	B1	B2	H1	H2	a	c	c'	e					
300×300	500	-	-	465	435	300	300	100	70	420				
×400				565	B535		400				485			
×500				665	635		500					550		
×600				765	735		600						615	
×700				865	835		700							680
×800				965	935		800		90		900			
×900				1065	1035		900					980		
×1000				1165	1135		1000						1060	
×1100				1265	1235		1100							1140
×1200				1365	1335		1200							
400×400	610	500	110	580	547	400	400	115	75	570				
×500				680	647		500				640			
×600				785	747		600					710		
×700				880	847		700						780	
×800				980	947		800							850
×900				1080	1047		900		95		1080			
×1000				1180	1147		1000					1170		
×1100				1280	1247		1100						1260	
×1200				1380	1347		1200							
500×500				710	500		210		696		662	500	500	130
×600	796	762	600			776								
×700	896	862	700					862						
×800	996	962	800						948					
×900	1096	1062	900							1110				
×1000	1196	1162	1000			1206								
×1100	1296	1262	1100					1302						
×1200	1396	1362	1200						1398					

蓋 版

集水用コンクリート蓋版

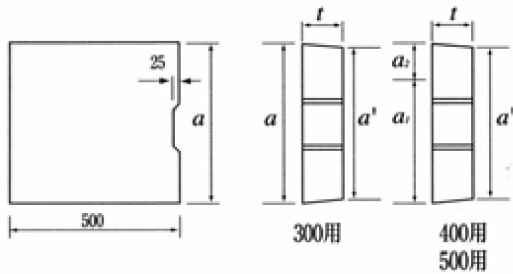

寸法・重量

呼び	寸 法 (mm)					参考重量 (kg)
	a	a'	a ₁	a ₂	t	
300用	400	380	-	-	100	43
400用	500	480	440	50	115	62
500用	600	580	440	150	130	95

グレーチング蓋版 (かさ上げタイプ) (固定式)

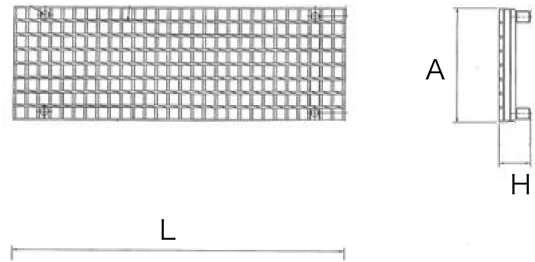

街路用 グレーチング 寸法・重量

呼び	寸法 (mm)			参考重量 (kg)
	A	H	L	
300用	400	95	995	37
400用	500	110	995	49
500用	600	125	995	71

施工断面図

標準断面

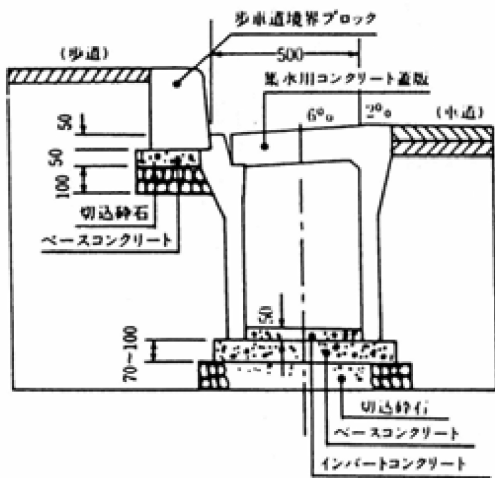

泥溜り部断面

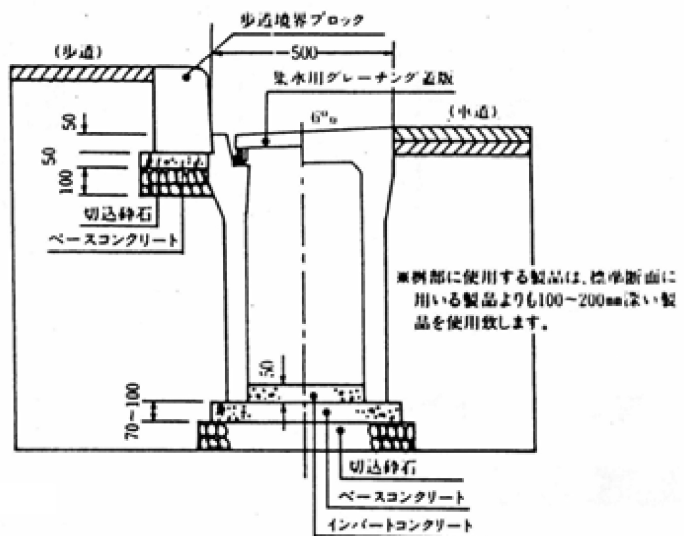

大型VS

〔注文製品ですので、納入数、期日の御連絡をお願いいたします〕

本体(水路巾700~1,000mmのもの)

規格図

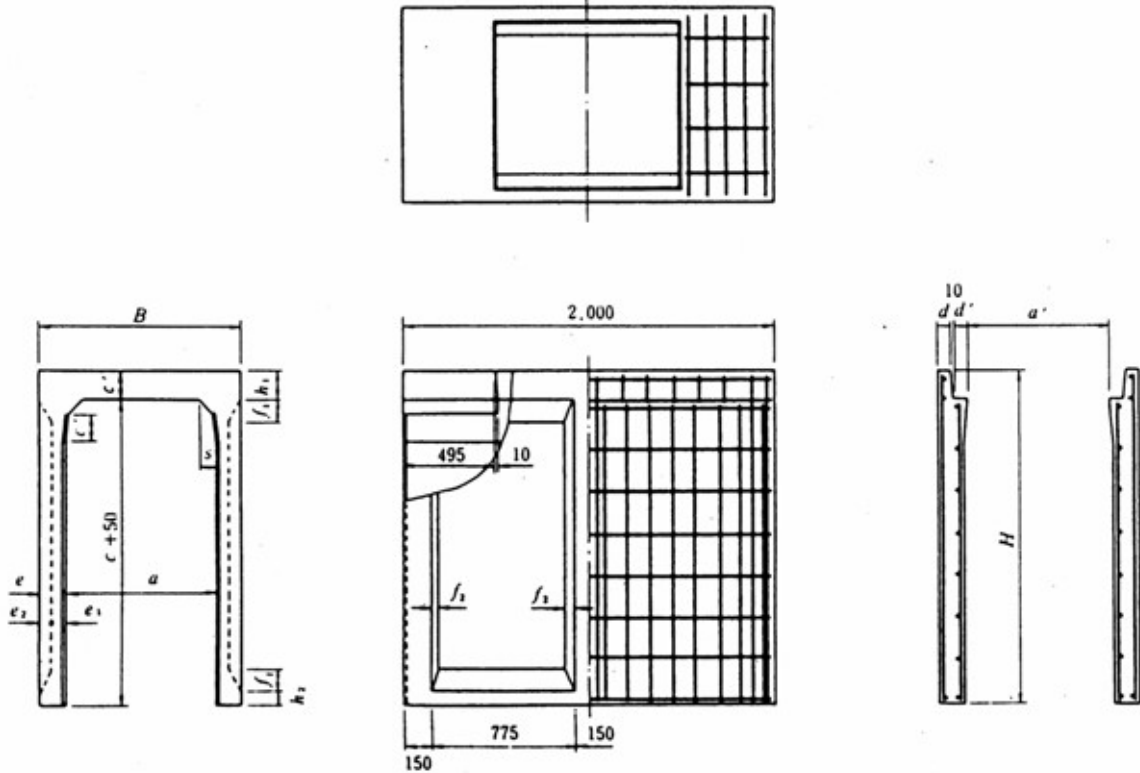

鉄筋コンクリート蓋版

規格図

(車道用)

(歩道用)

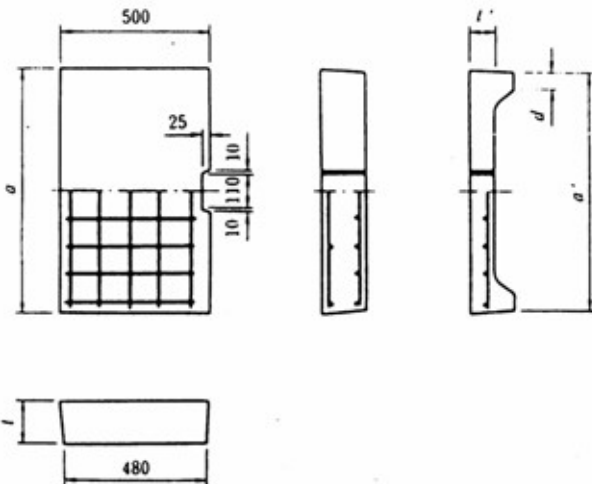

寸法・重量

呼び	寸法 (mm)					参考重量 (kg)
	a	a'	d	t	t'	
車道用	700用	820	800	-	150	137
	800用	920	900		160	165
	900用	1,030	1,010		170	196
	1,000用	1,130	1,110		180	228
歩道用	700用	820	800	55	150	85
	800用	920	900		160	90
	900用	1,030	1,010	60	170	95
	1,000用	1,130	1,110		180	100

寸法・重量

呼び (巾×深)	寸法 (mm)																参考重量 (kg)	
	B	H	a	a'	c	c'	d	d'	e	e1	e2	f1	f2	h1	h2	ℓ		s
700×500		700			500													935
×600		800			600													1,010
×700		900			700													1,087
×800		1,000			800													1,164
×900		1,100			900													1,242
×1,000		1,200			1,000													1,320
×1,100	970	1,300	700	670	1,300	150	70	70	135	65	70	120	40	150	80	100	70	1,397
×1,200		1,400			1,200													1,475
×1,300		1,500			1,300													1,557
×1,400		1,600			1,400													1,635
×1,500		1,700			1,500													1,713
×1,600		1,800			1,600													1,790
×1,700		1,900			1,700													1,868
800×600		810			600													1,120
×700		910			700													1,200
×800		1,010			800													1,279
×900		1,110			900													1,361
×1,000		1,210			1,000													1,444
×1,100		1,310			1,100													1,526
×1,200	1,080	1,410	800	768	1,200	160	75	71	140	70	70	120	40	160	80	100	80	1,608
×1,300		1,510			1,300													1,691
×1,400		1,610			1,400													1,778
×1,500		1,710			1,500													1,860
×1,600		1,810			1,600													1,942
×1,700		1,910			1,700													2,025
×1,800		2,010			1,800													2,107
900×700		920			700													1,310
×800		1,020			800													1,400
×900		1,120			900													1,483
×1,000		1,220			1,000													1,570
×1,100		1,320			1,100													1,657
×1,200		1,420			1,200													1,744
×1,300	1,190	1,520	900	866	1,300	170	75	77	145	75	70	120	40	170	80	100	90	1,831
×1,400		1,620			1,400													1,918
×1,500		1,720			1,500													2,010
×1,600		1,820			1,600													2,097
×1,700		1,920			1,700													2,184
×1,800		2,020			1,800													2,271
×1,900		2,120			1,900													2,358
1,000×800		1,030			800													1,530
×900		1,130			900													1,620
×1,000		1,230			1,000													1,705
×1,100		1,330			1,100													1,797
×1,200		1,430			1,200													1,889
×1,300		1,530			1,300													1,980
×1,400	1,300	1,630	1,000	964	1,400	180	80	78	150	80	70	120	40	180	80	100	100	2,072
×1,500		1,730			1,500													2,164
×1,600		1,830			1,600													2,261
×1,700		1,930			1,700													2,352
×1,800		2,030			1,800													2,444
×1,900		2,130			1,900													2,536
×2,000		2,230			2,000													2,627

グレーティング蓋版(固定式) 規格図 (かさ上げタイプ)

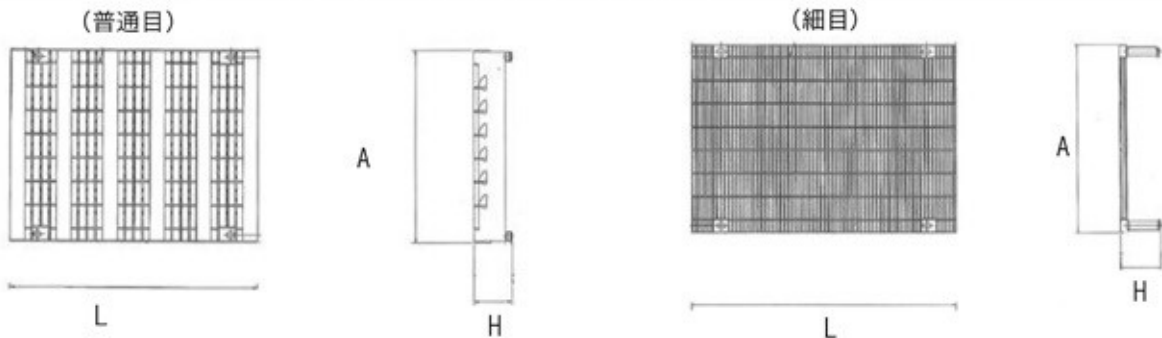

大型用 グレーティング 寸法・重量					
呼び	寸法(mm)			参考重量(kg)	
	A	H	L	普通目	細目
700用	810	150	990	128	132
800用	910	160	990	145	161
900用	1020	170	990	162	177
1000用	1120	180	990	190	206